

## Company Directive

### STANDARD TECHNIQUE : SD5D/2

### Relating to Arrangements for LV Cut-Outs

#### Policy Summary

This Standard Technique specifies standard LV cut-out arrangements for metering purposes.

**Author:** Andy Hood

**Implementation Date:** February 2013

**Approved by**



**Policy Manager**

**Date:**

28 February 2013

## 1.0 REVISION HISTORY

<b>Date</b>	<b>Changes / Comments</b>	<b>Author</b>
04/02/2013	<ul style="list-style-type: none"><li>• Requirements for multi-service distribution boards have been removed as these are now covered in ST:SD5C</li><li>• The arrangements described in section 3.1.3 and in figures 2A, 2B, 2C and 2D are only applicable where the mains cable or overhead line is single phase.</li></ul>	A Hood

## 2.0 INTRODUCTION

This document specifies the standard LV cut-out arrangements used for metered connections and should be read in conjunction with ST:SD6B (Connection Design for Low Voltage loads between 69kVA and 1000kVA).

Requirements for multi-service distribution boards are defined in ST:SD5C (Low Voltage Connections to Multi-occupancy Buildings).

## 3.0 POLICY

The document covers the following phase connections:

- Single-phase
- Split-phase
- Two-phase (two phases of a three-phase system)
- Three-phase

The arrangements and fuses sizes specified in this document are applicable to new or substantially modified installations.

Any single-phase, split-phase or two-phase installation that could be confused with a three-phase installation should carry a label, installed in a prominent position close to the cut-out/s. Labels are ordered using the order form available from the Corporate Print section within the Purchasing Catalogue.

### **Not Compatible Label (WPD Ref. W400149)**



### 3.1 Single-phase Connections

Single-phase connections are normally provided up to 80A per phase as standard. For connections above this value the preferred option is to utilise a three-phase or split-phase connection. If only single phase mains is available, for example, where a single phase transformer has been installed connections up to 160A can be provided.

CT metering shall not be provided for new or substantially modified single-phase connections.

#### 3.1.1 Single-phase loads up to 80A

Single-phase connections are normally restricted to 80A to prevent the 100A cut-out overheating in hot conditions. The maximum cut-out fuse rating is 80A, although in some specific cases the load is restricted to less than 80A by the use of smaller cut-out fuses, for example in some multi-occupancy buildings.

*Page Revised 20<sup>th</sup> May 2013*

The service cable and the tails connected to the cut-out shall be rated at, or above, the cut-out fuse rating, taking account of the installation method.

Figure 1A, 1B and 1C show standard connection arrangements and a typical metering arrangement is shown in Figure 1D.

### 3.1.2 Single-phase loads from 80A to 100A

100A cut-outs used in relatively cool conditions can deliver up to 100A of load. Where single-phase load is between 80A and 100A the preferred option is to provide a split-phase or three-phase connection or to use the method described in 3.1.3. Alternatively, it is sometimes possible to insert a 100A cut-out fuse and utilise the full 100A rating of a single-phase cut-out. This option may only be used where all the following conditions are satisfied:

- 100A DMC (dough moulded clay) type cut-out is installed. This is the current grey coloured cut-out specified by WPD.
- Service cable is rated at 100A or above (e.g. 35mm<sup>2</sup> hybrid or 25mm<sup>2</sup> copper concentric cable).
- Ambient temperature at the cut-out position will be 20°C or less during the maximum demand. This may be assumed where the cut-out is installed away from any heat sources and maximum demand occurs during the night or during winter/cold periods.
- A “100A Label”, WPD reference W400189, shall be installed adjacent to the cut-out to notify the meter operator that 100A metering is required.

#### **100A label (WPD ref. W400189)**

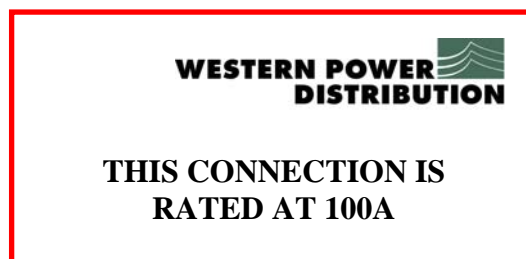

In all other respects the connection arrangements are identical to those described in 3.1.1. and Figure 1A, 1B, 1C and 1D.

### 3.1.3 Single-phase loads from 80A to 160A

These connections shall only be used where the mains cable or overhead line only has a single phase available. In all other cases a poly-phase (i.e. three-phase, split-phase or two-phase) connection shall be provided as this reduces the unbalance on the network. The connection is derived from a three-phase service cable, 100A three-phase cut-out and poly-phase metering. Further information is provided in Figure 2A, 2B and 2C.

WPD's 100A three-phase DMC type cut-outs (current grey coloured cut-outs) have been type tested for this duty. Other types of cut-out must not be used.

The maximum cut-out fuse used with this arrangement is 80A and the service cable rated at 80A per phase or higher.

A 25mm<sup>2</sup> copper tail (minimum) is used to connect together the two cores used for the neutral.

Any bunched connections must be made above ground (see section 3.5).

A “Not Compatible Label”, WPD reference W400149, shall be installed adjacent to the cut-out to warn that 3 phases are not available.

The customer must split their load into two groups, each of which is connected to a separate cut-out. A typical arrangement is shown in Figure 2D.

## 3.2 Split-phase / Two-phase Connections

Split-phase connections are derived from split-phase transformers or in some cases from three-phase transformers connected in a split-phase configuration. The two phases operate 180 degrees apart and, in a perfectly balanced system, no current flows in the neutral.

Two-phase connections are derived from two separate phases of a three-phase system. In this case the phases operate 120 degrees apart and, in a perfectly balanced arrangement, neutral current will be equal to the phase current. As a result, the service voltage drop will be greater than for a balanced split-phase or three-phase connection.

Two-phase connections shall not be provided where the mains cable or overhead line has three-phases available.

### 3.2.1 Split-phase and two-phase loads up to 80A per phase

Split-phase and two-phase connections up to 80A per phase are derived from a 3-phase service cable and 100A cut-out. The maximum cut-out fuse rating is 80A and the service is rated at, or above, the fuse size. Further information is provided in Figure 3A, 3B and 3C and a typical metering arrangement is shown in Figure 3D.

A 25mm<sup>2</sup> copper tail (minimum) is used to connect the third core to the neutral.

A “Not Compatible Label”, WPD reference W400149, shall be installed adjacent to the cut-out to warn that 3 phases are not available.

### 3.2.2 Split-phase and two-phase loads from 80A to 100A per phase

Loads above 80A per phase should, as far as reasonably practicable be provided using a split-phase or three-phase connection utilising a heavy duty cut-out and mains cable (e.g. wavecon).

Alternatively, it is sometimes possible to use 100A cut-out fuses and utilise the full rating of the cut-out. This option may only be used where all the following conditions are satisfied:

- 100A DMC (dough moulded clay) type cut-out is installed. This is the current grey-coloured cut-out specified by WPD.
- Service cable is rated at 100A or above (e.g. 35mm<sup>2</sup> hybrid or 25mm<sup>2</sup> copper concentric cable).
- Ambient temperature at the cut-out position will be 20°C or less during the maximum demand. This may be assumed where the cut-out is installed away from any heat sources and maximum demand occurs during the night or during winter/cold periods.

- A “100A label”, WPD reference W400189, shall be installed adjacent to the cut-out to notify the Meter Operator that 100A metering is required (see 3.1.2 for label requirements).
- A “Not Compatible Label”, WPD reference W400149, shall be installed adjacent to the cut-out to warn that 3 phases are not available.

In all other respects the connection arrangements are identical to those described in 3.2.1.

### 3.2.3 Split-phase and two-phase loads above 80A per phase

The maximum capacity for two-phase connections is 100A per phase. CT metering is not available for new or substantially modified two-phase installations.

The maximum capacity for split-phase connections is limited by mains cable and distribution transformer ratings. The largest split-phase transformer used as standard is 100kVA, although in South Wales Area larger three-phase transformers are sometimes connected in split-phase configuration to provide increased capacity.

CT metering is required for all split phase loads above 100A per phase.

Mains cable entry requirements are specified in Section 3.10.

The cut-out fuse size must be rated at, or below, the cut-out and mains cable ratings.

A “Not Compatible Label”, WPD reference W400149, shall be installed adjacent to the cut-out to warn that 3 phases are not available.

Further information is provided in Figure 4A, 4B and 4C.

## 3.3 **Three-phase Connections**

### 3.3.1 Three-phase loads up to 80A per phase

Three-phase connections up to 80A per phase are derived from a 100A cut-out and three-phase service cable. The maximum cut-out fuse rating is 80A and the service must be rated at, or above, the cut-out fuse.

Figure 5A, 5B and 5C show standard connection arrangements for PME, SNE and directly earthed installations. A typical metering arrangement is shown in Figure 5D

### 3.3.2 Three-phase loads from 80A to 100A per phase

Three-phase loads above 80A per phase should, as far as reasonably practicable be provided from a heavy duty cut-out and mains cable (e.g. wavecon).

Alternatively, it is sometimes possible to insert 100A cut-out fuses and utilise the full rating of a 100A cut-out. This option may only be used where all the following conditions are satisfied:

- 100A DMC (dough moulded clay) type cut-out is installed. This is the current grey-coloured cut-out purchased by WPD.
- Service cable is rated at 100A or above (e.g. 35mm<sup>2</sup> hybrid or 25mm<sup>2</sup> copper concentric cable).

- Ambient temperature at the cut-out position will be 20°C or less during the maximum demand. This may be assumed where the cut-out is installed away from any heat sources and maximum demand occurs during the night or during winter/cold periods.
- A “100A label”, WPD reference W400189, shall be installed adjacent to the cut-out to notify the Meter Operator that 100A metering is required (see 3.1.2 for label requirements).

In all other respects the connection arrangements are identical to those described in 3.3.1.

### 3.3.3 Three-phase loads above 80A per phase

Three-phase loads above 80A are normally derived from a three-phase mains cable (e.g. wavecon) and a combined cut-out/CT metering panel. The maximum capacity is dictated by cut-out and cable ratings.

Mains cable entry requirements are specified in Section 3.10.

The cut-out fuse must be rated at, or below the rating of the cut-out and mains cable.

CT metering is required where the load is above 100A per phase.

Figure 6A, 6B and 6C provide further information.

## 3.4 **Looped Services**

In order to prevent cut-outs from overheating, service cables shall not normally be looped from the bottom of cut-outs.

It is only acceptable to loop from the bottom of a cut-out for the purposes of providing a landlords or building services supply. In addition, all the following conditions must be satisfied:

- Only one looped connection may be provided.
- The total load of the main connection and looped connection must be assessed as being well below the rating of the incoming cable and cut-out.
- The rating of the incoming cut-out and incoming cable must be equal to, or greater than, the summated ratings of the main cut-out fuse and looped cut-out fuse.
- The looped service must be terminated in a cut-out within the same building as the incoming connection and both cut-outs must be located within 5m of each other.

## 3.5 **Bunching Service Cables**

Standard split-phase, two phase and, in some cases, single-phase arrangements require the cores of three-phase cables to be bunched together. It can also be helpful to bunch cores together to reduce voltage drop on long single-phase services. In order to minimise the risk of confusion the following steps shall be taken:

- Bunching is normally only allowed above ground (i.e. where the connections can be visually inspected, for example at pole terminations and cut-outs. The only exception is for split phase and two phase connections where a service cable is jointed to a mains cable that only has two phase conductors (i.e. a 2 core combined neutral and earth cable or a 3 core separate and neutral cable).

- Bunching shall be noted on WPDs maps.
- Incoming cables shall always be terminated colour true at each cut-out. Additional, adequately rated loops (between the bottom cut-out terminals) shall be installed where bunching is required.

### 3.6 Earthing

For each arrangement described, diagrams show PME, SNE and direct earthing arrangements. PME earthing is preferred where this can be provided economically and safely.

A suitable label (PME, SNE or direct earthing) shall be placed in a prominent position close to the cut-out. Standard labels are given below and can be ordered using the order form available from the Corporate Print section of the Purchasing Catalogue.

#### PME Label (WPD Ref. 400133)

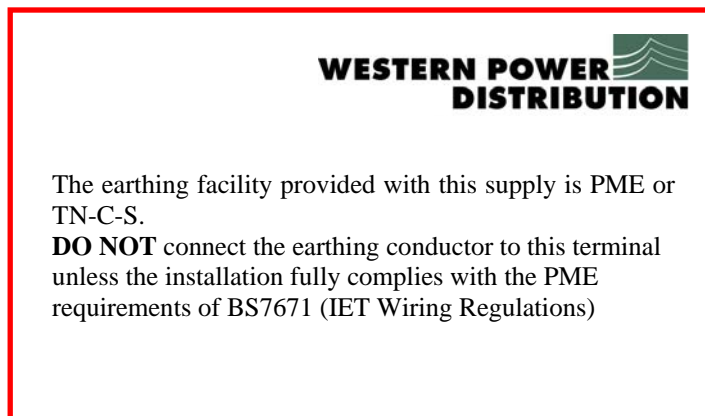

#### SNE / Cable Sheath Earth Label (WPD Ref. W400171)

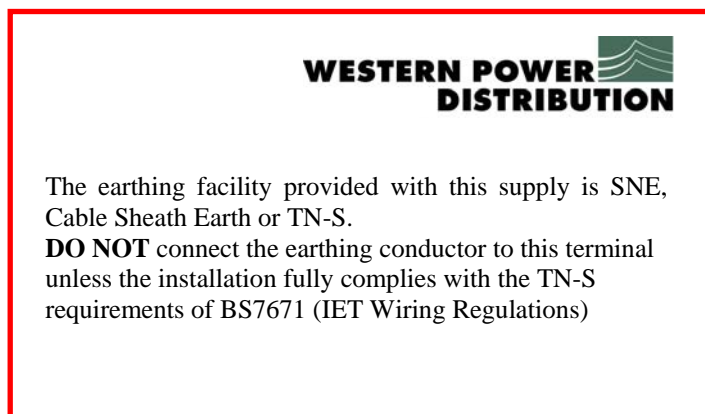

*Page Revised 20<sup>th</sup> May 2013*



## Direct Earthing Label (WPD Ref. W400188)

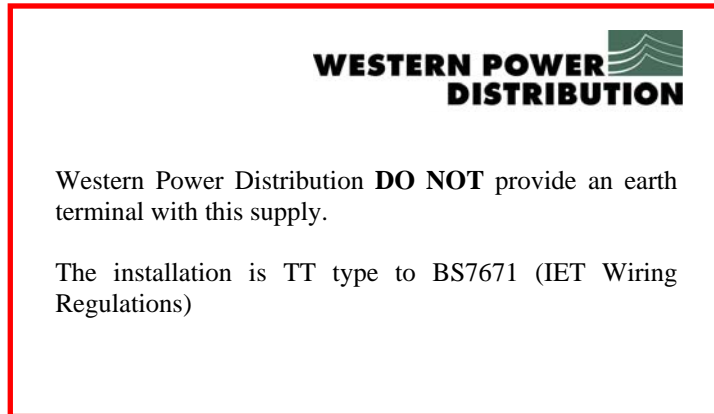

### 3.7 Isolation Switches

Isolation switches are sometimes installed by WPD at existing installations at the request of the customer (for example, if we are requested to temporarily de-energise a connection).

The switch is inserted between the meters and the customer's equipment and isolates both phase and neutral. The isolation switch must not, under any circumstances be placed between the service cable and the customer's cut-out.

The following label, which can be ordered from the Corporate Printing section of the Purchasing Catalogue shall be placed in a prominent position close to the isolation switch:

### Isolation Switch Label (WPD Ref. W400006)

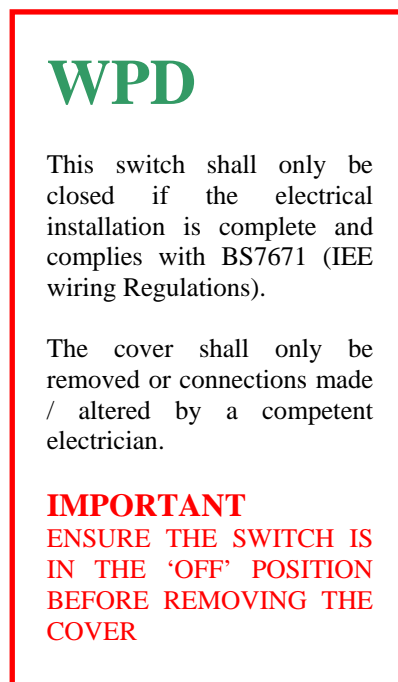

*Page Revised 20<sup>th</sup> May 2013*

Three types of isolation switch are available as follows:

- 2 pole 100A isolator for standard single-phase connections.
- 4 pole 100A isolator for off peak (e.g. economy 7) connections.
- 4 PLE 100A isolator for standard 3 phase connections.

The correct isolation switch (i.e. with appropriate terminal labelling) shall be installed for the application. Where a switch is fitted, it is essential that it disconnects all supplies at the exit point. For example, it is not acceptable to fit an isolation switch for the restricted (off peak) load only. Where all the supplies cannot be controlled by a single isolation switch it is acceptable to fit additional switches as long as they are all placed in close proximity to each other and they are clearly labelled (to identify their individual functions).

A Photograph of a single-phase and three-phase isolation switch is provided in Figure 8 and typical application is drawn in Figure 7.

### **3.8 Service / Meter Positions**

For domestic installations external meter cabinets are preferred.

Where cut-outs, multi-service distribution boards and/or metering installed within a building the installation should satisfy the following requirements:

- a) Height - the installation must not be too low or too high. The Meter Operator Code of Practice Agreement (MOCOPA) requires the cut-out and meter to be placed between 0.5m and 1.8m above floor/ground level.
- b) Access – the installation must be easily accessible and free from obstructions. Access routes must be kept clear and be well lit.
- c) Space - sufficient space shall be provided to allow for WPDs equipment, the metering to be easily installed, maintained and replaced. For connections derived from single-phase or three-phase 100A cut-outs, wall space of 600mm high x 400mm wide, dedicated to WPD's cut-out, the metering equipment and a small isolation switch, should be provided. In addition there should be at least 1m of space in front of the equipment to allow a person to work comfortably.

Space requirements for heavy duty cut-outs and CT metering are specified in ST:SD6B/2 and for multi-service distribution boards multi-occupancy buildings are defined in ST:SD5C.

- d) Environment - the environment must be weather proof, dry, free from heavy condensation and fairly cool (normally between 5°C and 20°C and in no circumstances above 30°C). There must be no significant heat sources in the vicinity that could overheat the equipment. For example, it is not acceptable to install meters in a warm airing cupboard.
- e) Proximity to Water - sources of water (e.g. taps, sink) must be kept well away from the installation to prevent water splashing the equipment or people with wet hands touching it. Cut-outs, meters and distribution boards shall not be installed within bathrooms, shower rooms, saunas or steam rooms.

- f) Proximity to Gas Meters - gas meters may be installed within the same room or enclosure as long as there is at least 300mm between the electrical installation and the gas meter. This distance may be ignored where the gas and electricity meters are each placed within separate meter cabinets.
- g) Vulnerability to Damage - equipment must not be placed where it exposed to accidental damage or vandalism.
- h) Fixing Arrangements - the wall on which Western Power Distribution's equipment and the meter operator's equipment is to be fixed shall be suitable for fixing / supporting the weight of this equipment. The customer / developer shall install suitable boarding (e.g. chipboard or plywood) to the back wall of the service / metering area so that meters and cut-outs can be screwed to this boarding.

### 3.9 Harmonised Phase Colours

At new and substantially modified connections, WPD shall fix the following label in a prominent position, near to the cut-out, where the installation uses a mixture of old and new phase colours. This label is available via the Corporate Print section of the Purchasing Catalogue.

#### Label for Installations with Mixed Wiring Colours (WPD Ref. W400166)

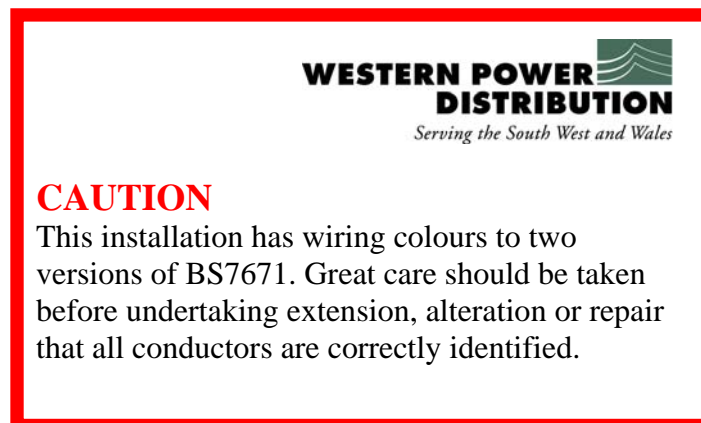

In addition the incoming supply cables shall be marked as follows:

#### Single-phase Cables

- Phase (brown or red) marked as L
- Neutral (blue or black) marked as N

#### Three-phase cables

- Phase 1 (brown or red) marked as L1
- Phase 2 (black or yellow) marked as L2
- Phase 3 (grey or blue) marked as L3
- Neutral conductor (blue or black) marked as N

Suitable tapes are available via SHOPS.

*Page Revised 20<sup>th</sup> May 2013*

### 3.10 Mains Cable Entry Requirements

General installation data for Western Power Distribution low voltage cables are given in Table 1, below. Cable de-rating factors are specified in ST:SD8B.

Figure 10 and 11 show two cable entry methods for wavcon cable, one using a draw pit and another using a duct with a slow bend. The slow bend duct option is only suitable for 95 wavecon cables.

**Table 1 Western Power Distribution Cable Installation Data**

Cable Type	Minimum Bending Radius (mm)	
	Single Phase	3 Phase
<b>Service Cables:</b>		
16mm <sup>2</sup> Copper Concentric	100	200
25mm <sup>2</sup> Copper Concentric	125	200
35mm <sup>2</sup> Copper Concentric	160	-
25mm <sup>2</sup> Hybrid	125	200
35mm <sup>2</sup> Hybrid	135	250
16mm <sup>2</sup> Copper Split Conc.	125	-
25mm <sup>2</sup> Copper Split Conc.	150	250
<b>Mains Cables:</b>		
95mm <sup>2</sup> Wavecon (3 core)	-	550
185mm <sup>2</sup> Wavecon (3 core)	-	700
300mm <sup>2</sup> Wavecon (3 core)	-	850
95mm <sup>2</sup> Wavecon (4 core)	-	600
185mm <sup>2</sup> Wavecon (4 core)	-	800
300mm <sup>2</sup> Wavecon (4 core)	-	1000

**FIGURE 1A**

**Single-phase PME Connection Arrangement; maximum load normally limited to 80A**

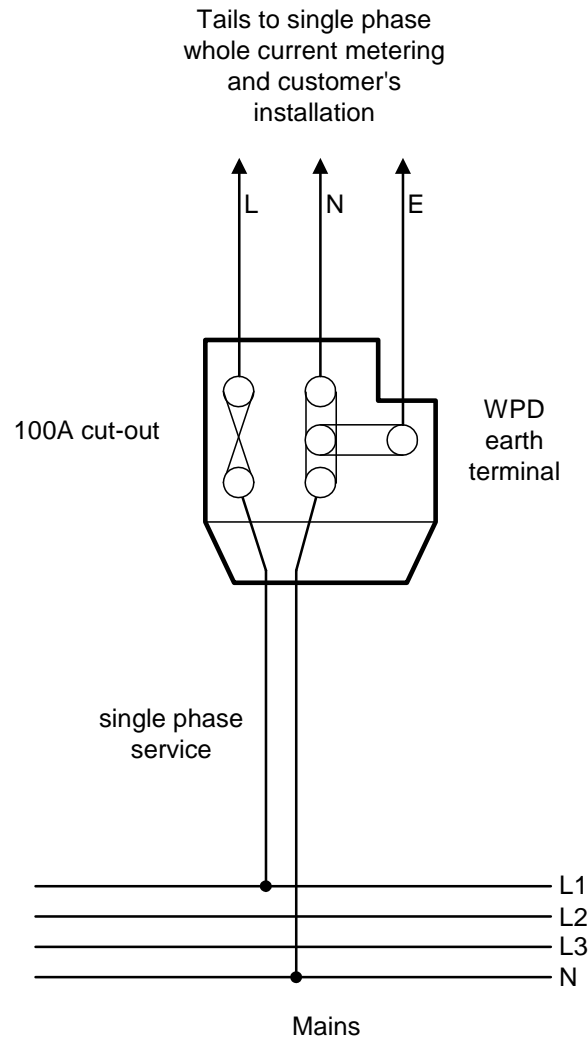

**Notes:**

- 1) Maximum cut-out fuse size is normally 80A;
- 2) Cut-out fuse size may be increased to 100A if the conditions defined in 3.1.2. are satisfied;
- 3) Service cable and meter tails must have continuous rating above cut-out fuse size;
- 4) A PME label shall be placed adjacent to cut-out.

**FIGURE 1B**

**Single-phase SNE Connection Arrangement; maximum load normally limited to 80A**

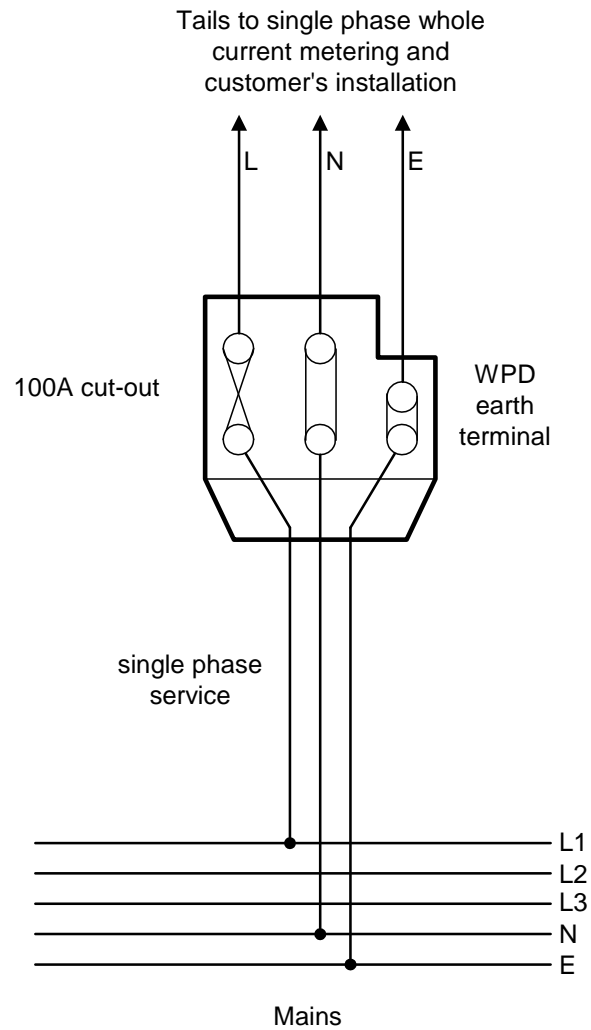

**Notes:**

- 1) Maximum cut-out fuse size is normally 80A;
- 2) Cut-out fuse size may be increased to 100A if the conditions defined in 3.1.2 are satisfied;
- 3) Service cable and meter tails must have continuous rating above cut-out fuse size;
- 4) A SNE label shall be installed adjacent to cut-out.

**FIGURE 1C**

**Single-phase Directly Earthed Connection Arrangement; maximum load normally limited to 80A**

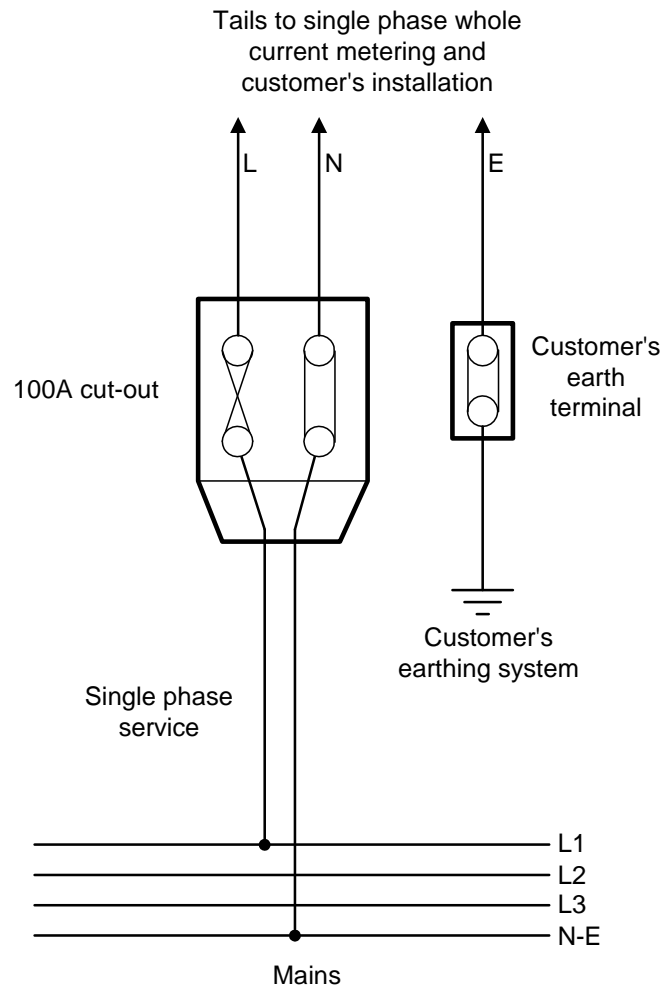

**Notes:**

- 1) Maximum cut-out fuse size is normally 80A;
- 2) Cut-out fuse size may be increased to 100A if the conditions defined in 3.1.2. are satisfied;
- 3) Service cable and meter tails must have continuous rating above cut-out fuse size;
- 4) Customer provides own earthing system and earthing terminal;
- 5) A direct earthing label shall be installed adjacent to cut-out.

**FIGURE 1D**

**Typical Metering / Customer Arrangement; Single phase connection with load normally limited to 80A**

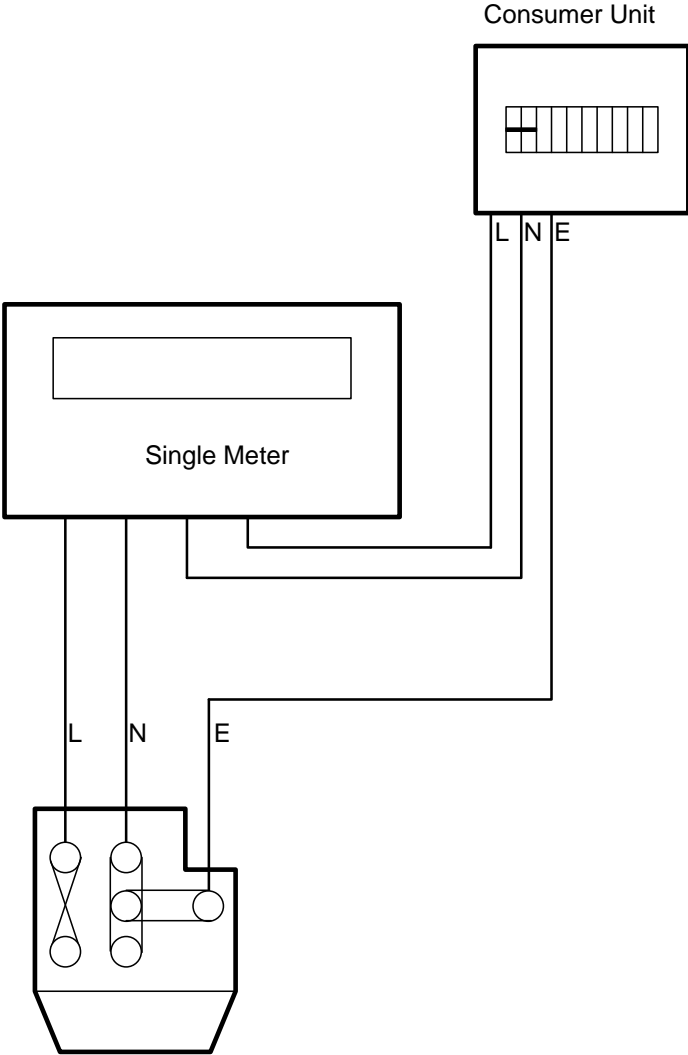



**FIGURE 2A**

**Single-phase PME Connection Arrangement; maximum load is between 80A and 160A**

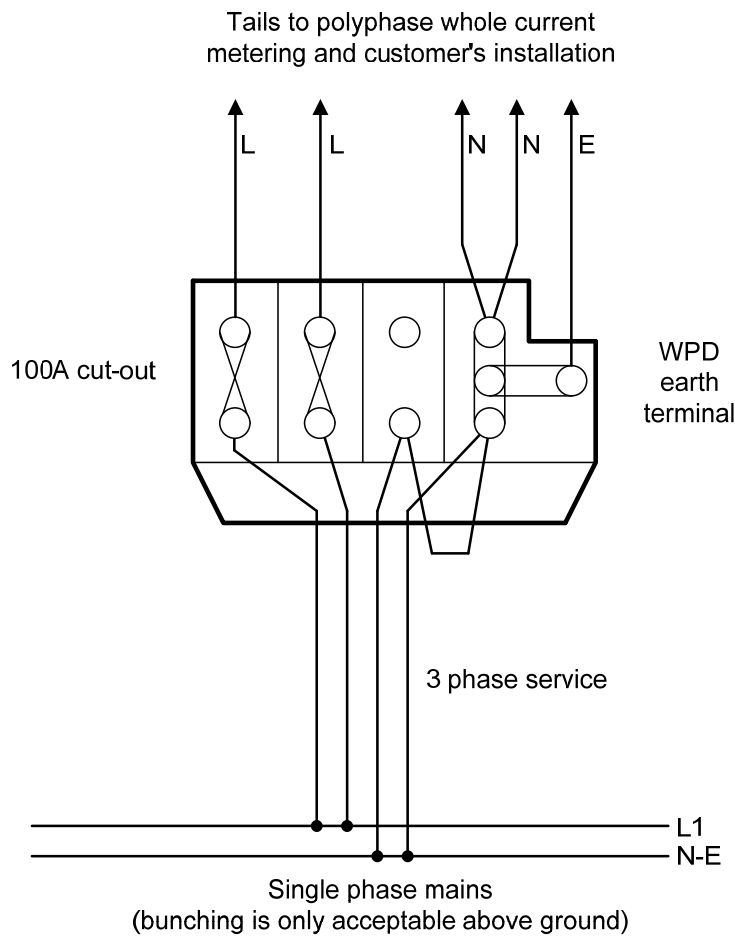

**Notes:**

- 1) WPD's 100A DMC type (grey coloured) cut-outs have been type tested for this duty. No other type of cut-out may be used for this application;
- 2) Maximum cut-out fuse size is 80A;
- 3) A label shall be placed at cut-out position reading "Warning this installation is not compatible with three-phase equipment";
- 4) Service cable must have a continuous rating above the cut-out fuse rating;
- 5) The spare phase of the service cable is bunched with the neutral to provide adequate neutral rating. 25mm<sup>2</sup> copper PVC/PVC cable is used to connect these two cores together at the cut-out;
- 6) A PME label shall be placed adjacent to cut-out;
- 7) Fuse carrier (with a dummy fuse inserted) shall be inserted in the spare fuse-way.

**FIGURE 2B**

**Single-phase SNE Connection Arrangement; maximum load is between 80A and 160A**

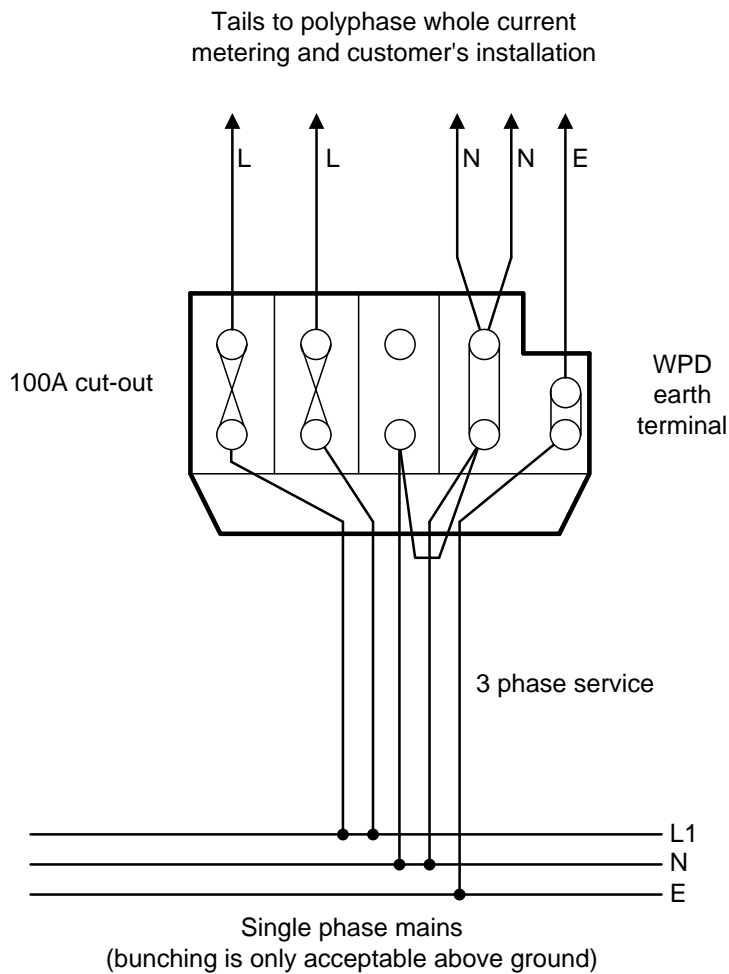

**Notes:**

- 1) WPD's 100A DMC type (grey coloured) cut-outs have been Type Tested for this duty. No other type of cut-out may be used for this application;
- 2) Maximum cut-out fuse size is 80A;
- 3) A sign shall be placed at cut-out position reading "Warning this installation is not compatible with three-phase equipment";
- 4) Service cable must have a continuous rating above the cut-out fuse rating;
- 5) The spare phase of the service cable is bunched with the neutral to provide adequate neutral rating. 25mm<sup>2</sup> copper PVC/PVC cable is used to connect these two cores together at the cut-out;
- 6) A SNE label shall be placed adjacent to cut-out;
- 7) Fuse carrier (with a dummy fuse inserted) shall be inserted in the spare fuse-way.

**FIGURE 2C**

**Single-phase Directly Earthed Connection Arrangement; maximum load is between 80A and 160A**

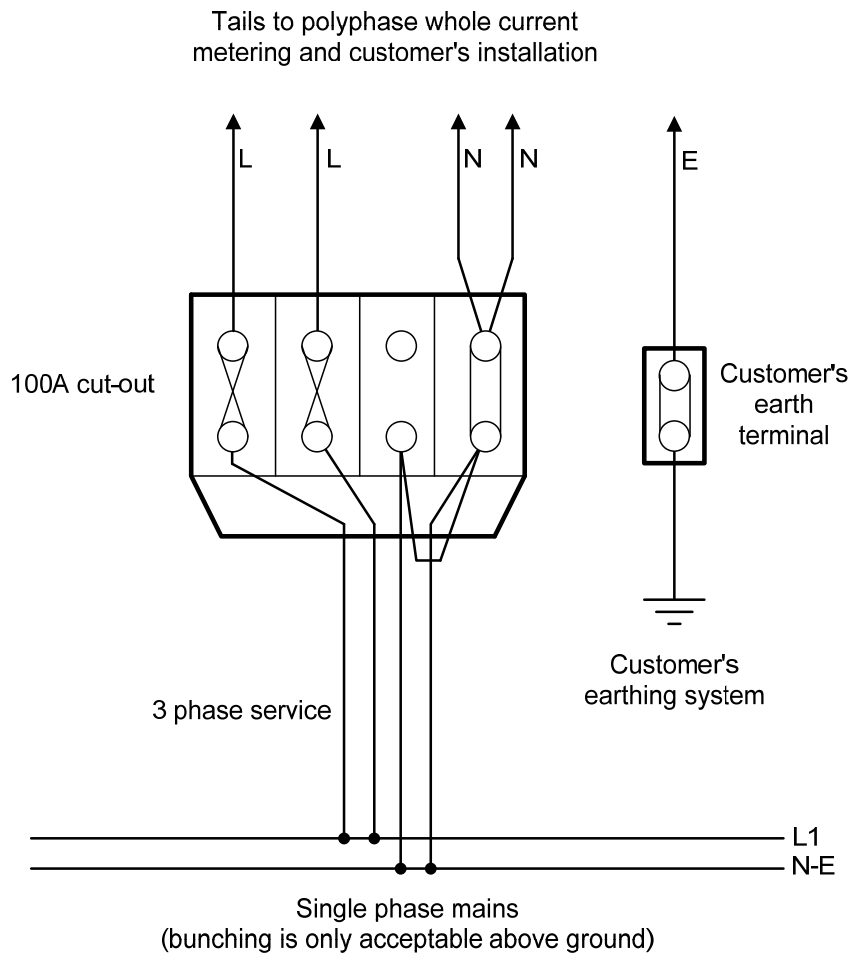

**Notes:**

- 1) WPD's 100A DMC type (grey coloured) cut-outs have been Type Tested for this duty. No other type of cut-out may be used for this application;
- 2) Maximum cut-out fuse size is 80A;
- 3) A sign shall be placed at cut-out position reading "Warning this installation is not compatible with three-phase equipment";
- 4) Service cable must have a continuous rating above the cut-out fuse rating;
- 5) The spare phase of the service cable is bunched with the neutral to provide adequate neutral rating. 25mm<sup>2</sup> copper PVC/PVC cable is used to connect these two cores together at the cut-out;
- 6) Customer provides own earthing system and earthing terminal;
- 7) A direct earthing label shall be placed adjacent to cut-out;
- 8) Fuse carrier (with a dummy fuse inserted) shall be inserted in the spare fuse-way;

**FIGURE 2D**

**Typical Metering / Customer Arrangement; single phase connection with poly-phase metering with a maximum load of 80A to 160A**

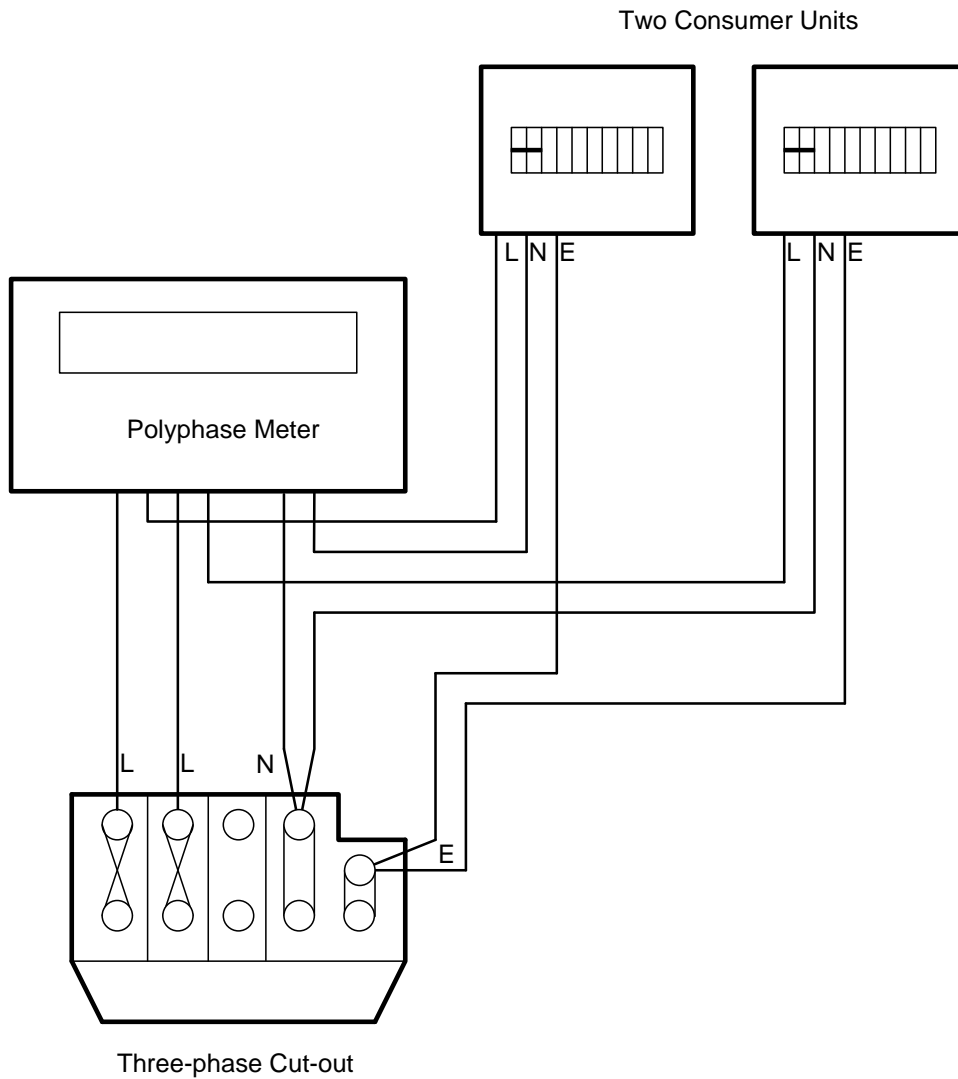

**Notes:**

- 1) Customer must split load into two separate groups. In this example two consumer units are shown, although the customer could use a multiphase distribution board instead.
- 2) Fuse carrier (with a dummy fuse inserted) shall be inserted in the spare fuse-way.

**FIGURE 3A**

**Split-phase or Two-phase PME Connection Arrangement;  
maximum load is normally limited to 80A per phase**

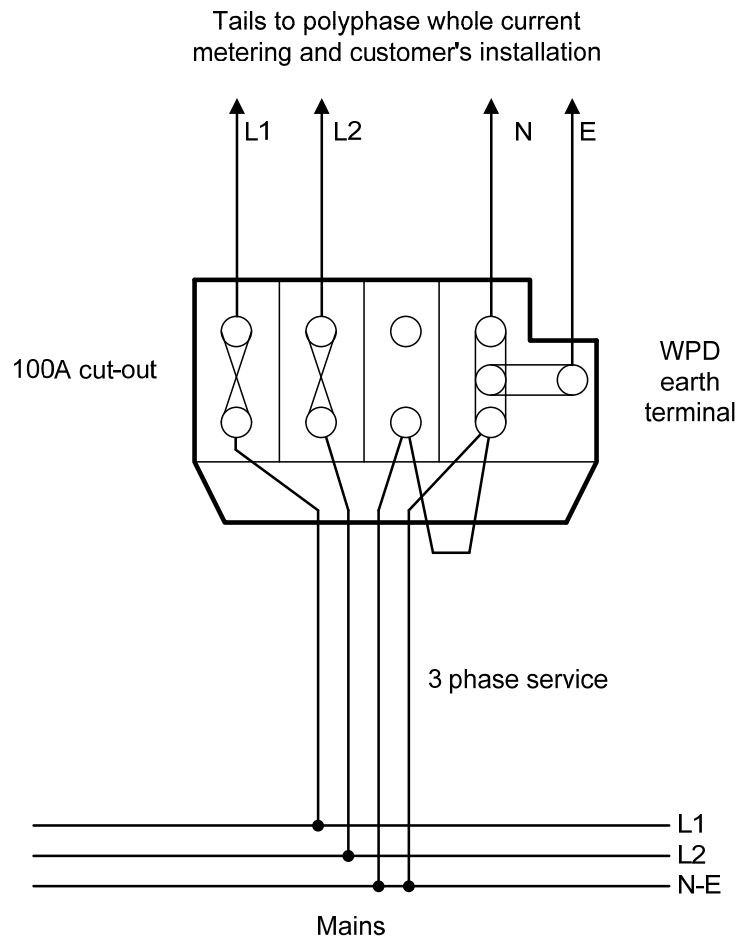

**Notes:**

- 1) Maximum cut-out fuse size is normally 80A;
- 2) Cut-out fuse size and maximum load may be increased to 100A if conditions in 3.2.2 are satisfied;
- 3) A sign shall be placed at cut-out position reading "Warning this installation is not compatible with three-phase equipment".
- 4) Service cable must have a continuous rating above the associated cut-out fuse rating.
- 5) The third core of the service cable is bunched with the neutral to minimise loop impedance. 25mm<sup>2</sup> copper PVC/PVC cable is used to connect these cores together at the cut-out. Where the mains cable only has two phase conductors the third core and neutral of the service cable may be bunched in the service joint. In all other cases bunching may only be carried out above ground.
- 6) A PME label shall be placed adjacent to cut-out.
- 7) Fuse carrier (with a dummy fuse inserted) shall be inserted in the spare fuse-way.

**FIGURE 3B**

**Split-phase or Two-phase SNE Connection Arrangement; maximum load is normally limited to 80A per phase**

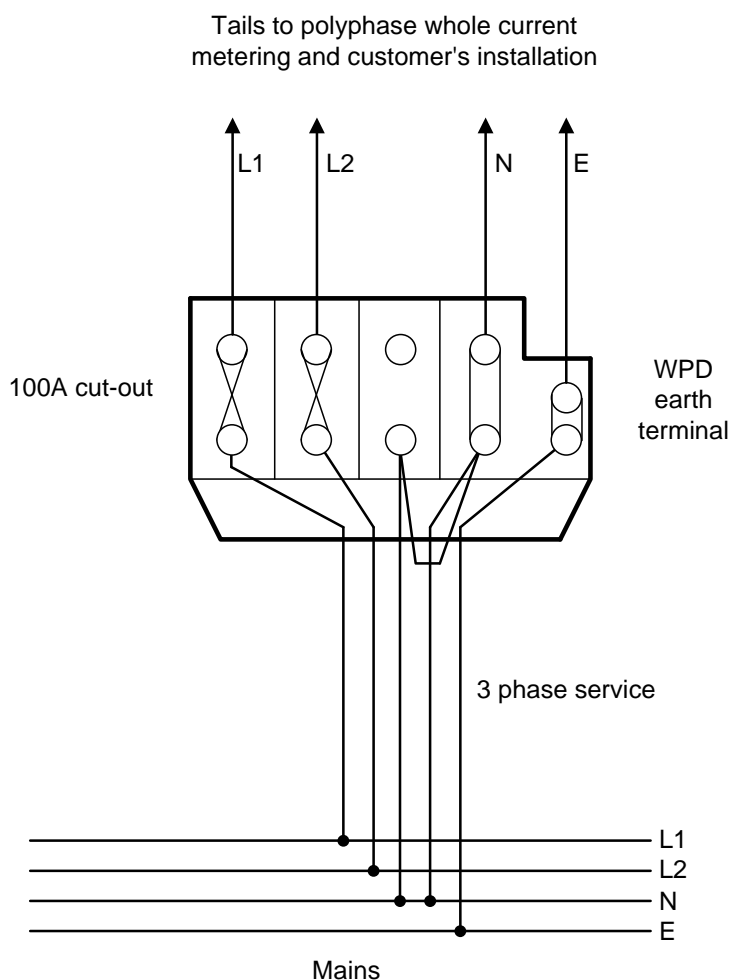

**Notes:**

- 1) Maximum cut-out fuse size is normally 80A;
- 2) Cut-out fuse size and maximum load may be increased to 100A if conditions in 3.2.2 are satisfied;
- 3) A label shall be placed at cut-out position reading “Warning this installation is not compatible with three-phase equipment”;
- 4) Service cable and meter tails must have a continuous rating above the cut-out fuse rating;
- 5) The third core of the service cable is bunched with the neutral to minimise loop impedance. 25mm<sup>2</sup> copper PVC/PVC cable is used to connect these cores together at the cut-out. Where the mains cable only has two phase conductors the third core and neutral of the service cable may be bunched in the service joint. In all other cases bunching may only be carried out above ground;
- 6) Fuse carrier (with a dummy fuse inserted) shall be inserted in the spare fuse-way.

**FIGURE 3C**

**Split-phase or Two-phase Directly Earthed Connection Arrangement;  
maximum load is normally limited to 80A per phase**

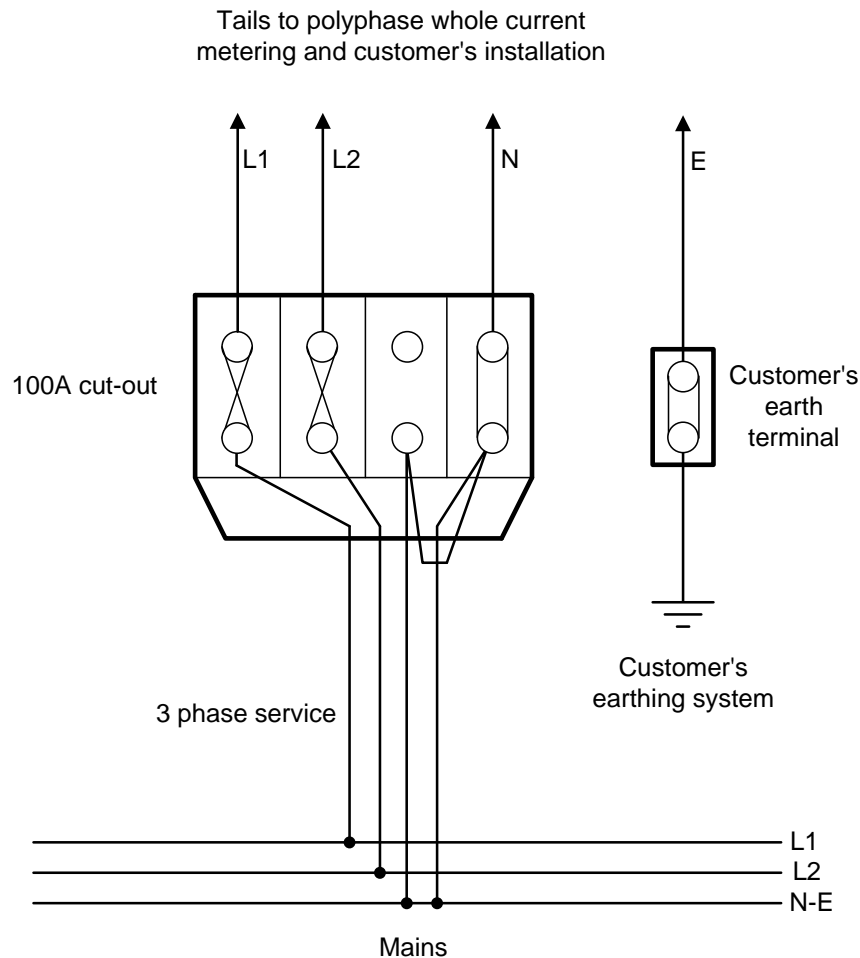

**Notes:**

- 1) Maximum cut-out fuse size is normally 80A;
- 2) Cut-out fuse size and maximum load may be increased to 100A if conditions in 3.2.2 are satisfied;
- 3) A sign shall be placed at cut-out position reading "Warning this installation is not compatible with three-phase equipment";
- 4) Service cable and meter tails must have a continuous rating above the associated cut-out fuse rating;
- 5) The third core of the service cable is bunched with the neutral to minimise loop impedance. 25mm<sup>2</sup> copper PVC/PVC cable is used to connect these cores together at the cut-out. Where the mains cable only has two phase conductors the third core and neutral of the service cable may be bunched in the service joint. In all other cases bunching may only be carried out above ground;
- 6) Customer provides own earthing system and earthing terminal;
- 7) A direct earthing label shall be placed adjacent to cut-out;
- 8) Fuse carrier (with a dummy fuse inserted) shall be inserted in the spare fuse-way.

**FIGURE 3D**

**Typical Metering / Customer Arrangement; split-phase or two-phase connection with poly-phase metering and with a maximum load normally limited to 80A per phase**

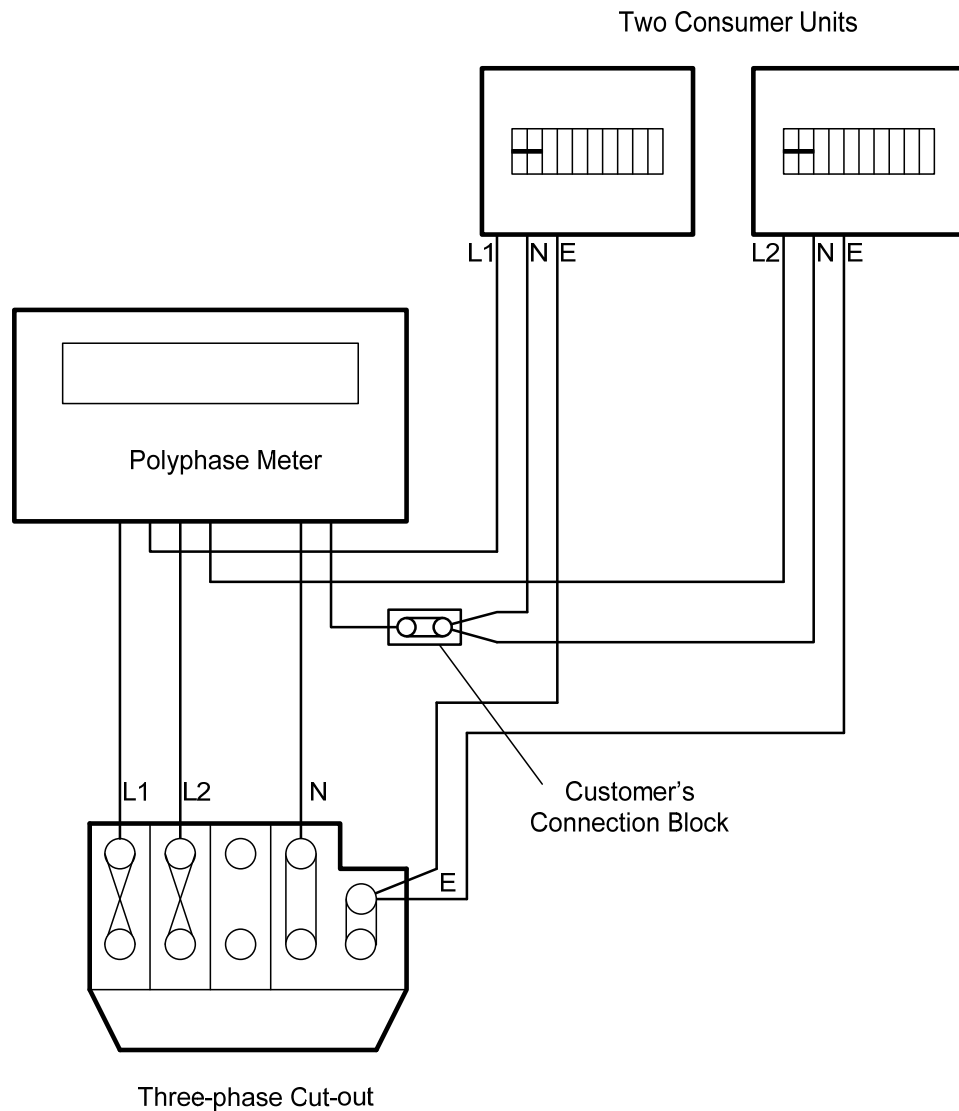

**Notes:**

- 1) The above arrangement utilizing two consumer units is only suitable if each item of load is single-phase. If a multi-phase load is installed (e.g. a split-phase motor) the tails must be terminated in a multiphase main switch so that both phases are switched / isolated together;
- 2) Fuse carrier (with a dummy fuse inserted) shall be inserted in the spare fuse-way.



**FIGURE 4A Split-phase PME Connection Arrangement; maximum load is above 80A per phase**

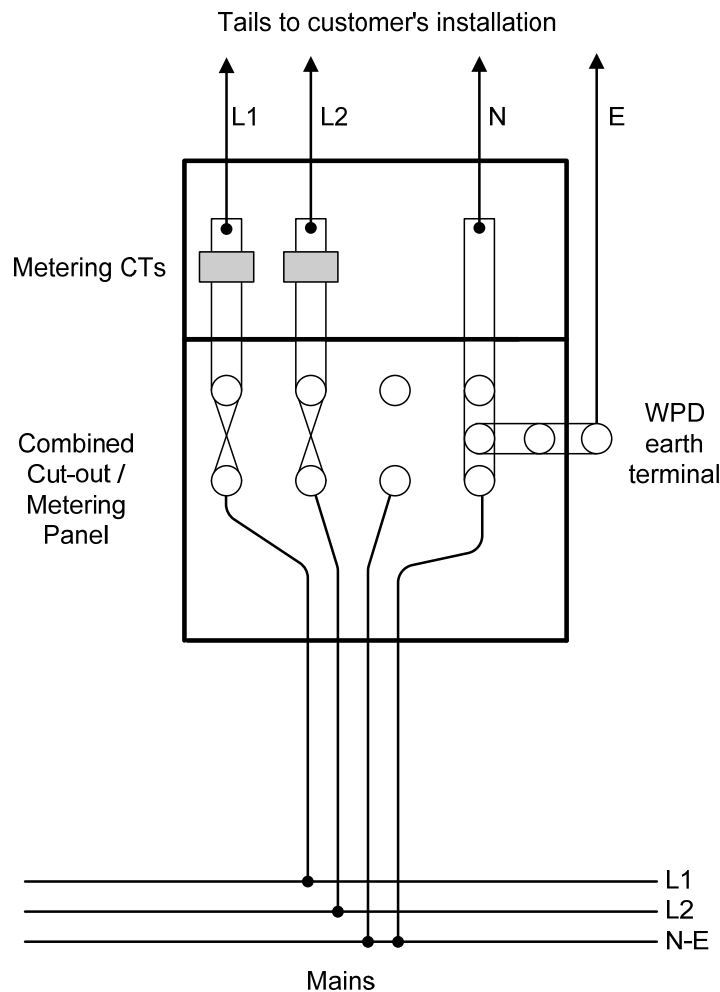

**Notes:**

- 1) Drawing is based on a combined cut-out / CT metering panel;
- 2) Poly-phase whole current metering may be used for loads up to 100A per phase. CT metering is required for loads over 100A per phase;
- 3) Incoming cable and meter tails must have a continuous rating above the cut-out fuse rating;
- 4) Sign to be placed at cut-out position reading “Warning this installation is not compatible with three-phase equipment”;
- 5) A PME label shall be placed adjacent to cut-out;
- 6) Spare fuse-way shall be shrouded;
- 7) Where the mains cable only has two phase conductors the third core and neutral of the service cable may be bunched in the service joint. In all other cases bunching may only be carried out above ground.

**FIGURE 4B**

**Split-phase SNE Connection Arrangement; maximum load is above 80A per phase**

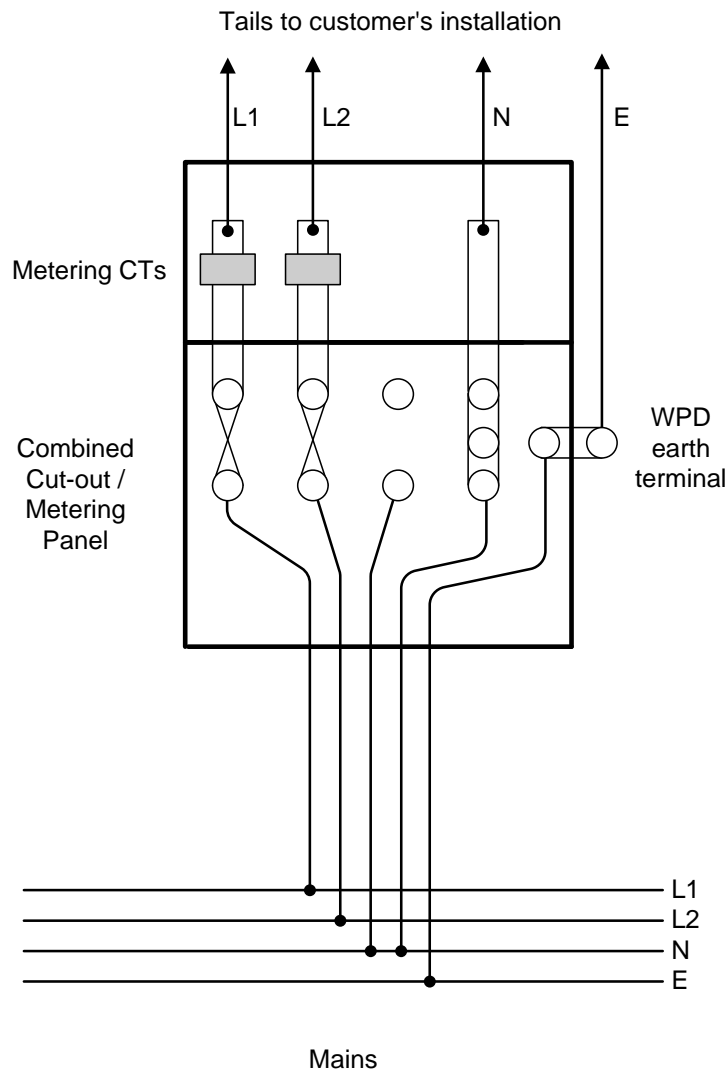

**Notes:**

- 1) Drawing is based on a combined cut-out / CT metering panel;
- 2) Polyphase whole current metering may be used for loads up to 100A per phase. CT metering (as shown above) is required for loads over 100A per phase;
- 3) Incoming cable and meter tails must have a continuous rating above the cut-out fuse rating;
- 4) Sign to be placed at cut-out position reading “Warning this installation is not compatible with three-phase equipment”;
- 5) A SNE label shall be placed adjacent to cut-out;
- 6) Spare fuse-way shall be shrouded;
- 7) Where the mains cable only has two phase conductors the third core and neutral of the service cable may be bunched in the service joint. In all other cases bunching must be carried out above ground.

**FIGURE 4C**

**Split-phase Directly Earthed Connection Arrangement; maximum load is above 80A per phase**

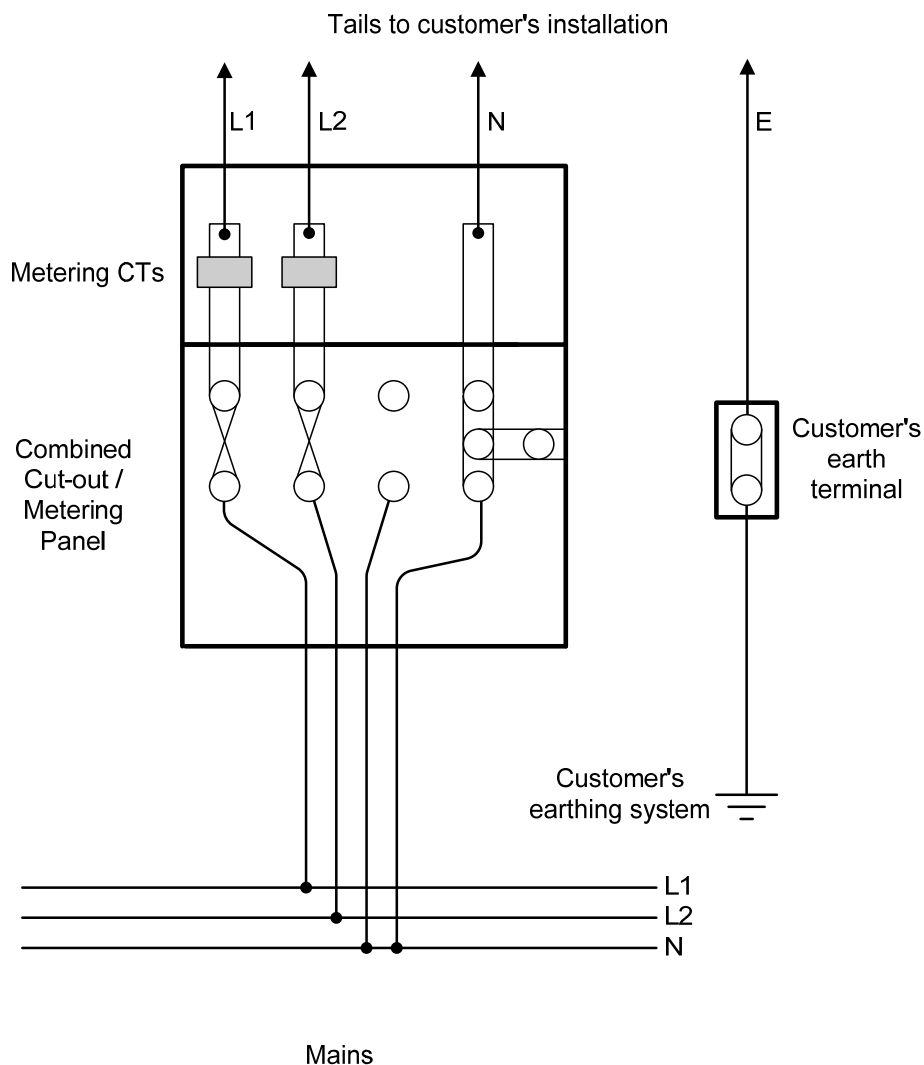

**Notes:**

- 1) Drawing is based on a combined cut-out / CT metering panel;
- 2) Polyphase whole current metering may be used for loads up to 100A per phase. CT metering is required for loads over 100A per phase;
- 3) Incoming cable and meter tails must have a continuous rating above the cut-out fuse rating;
- 4) Sign to be placed at cut-out position reading “Warning this installation is not compatible with three-phase equipment”;
- 5) Customer provides own earthing system and earthing terminal;
- 6) A direct earthing label shall be placed adjacent to cut-out;
- 7) Spare fuse-way shall be shrouded;
- 8) Where the mains cable only has two phase conductors the third core and neutral of the service cable may be bunched in the service joint. In all other cases bunching must be carried out above ground.

**FIGURE 5A**

**Three-phase PME Connection Arrangement; maximum load is normally limited to 80A per phase**

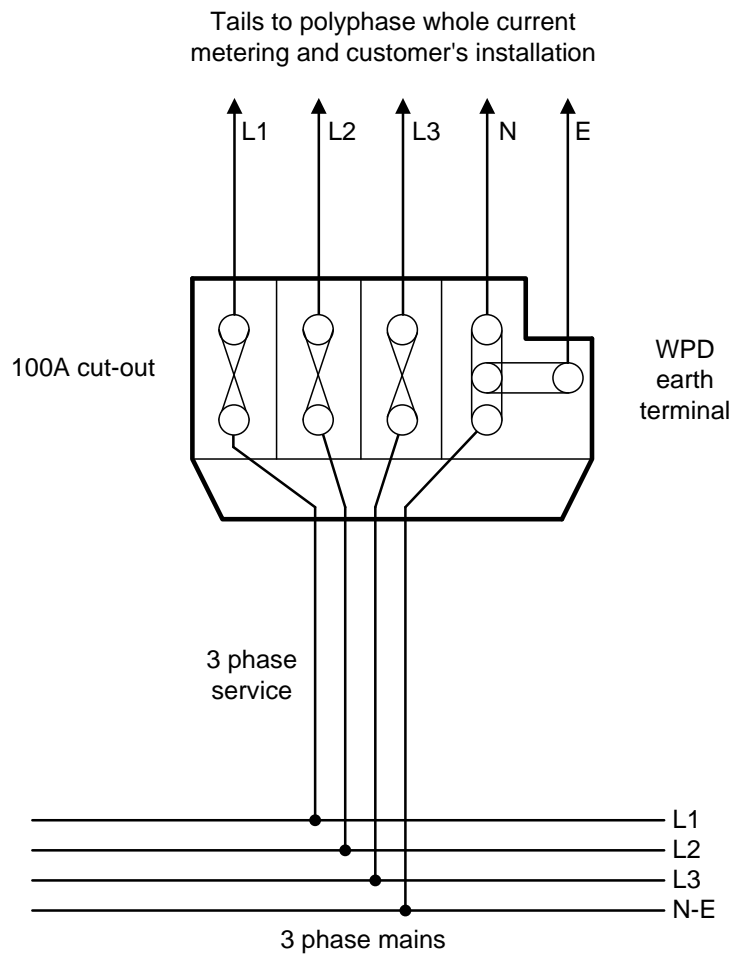

**Notes:**

- 1) Maximum cut-out fuse size is normally 80A;
- 2) Cut-out fuse size and maximum load may be increased to 100A if conditions in 3.3.2 are satisfied;
- 3) Service cable must have a continuous rating above the cut-out fuse size;
- 4) PME label shall be placed adjacent to cut-out.

**FIGURE 5B**

**Three-phase SNE Connection Arrangement, maximum load is normally limited to 80A per phase**

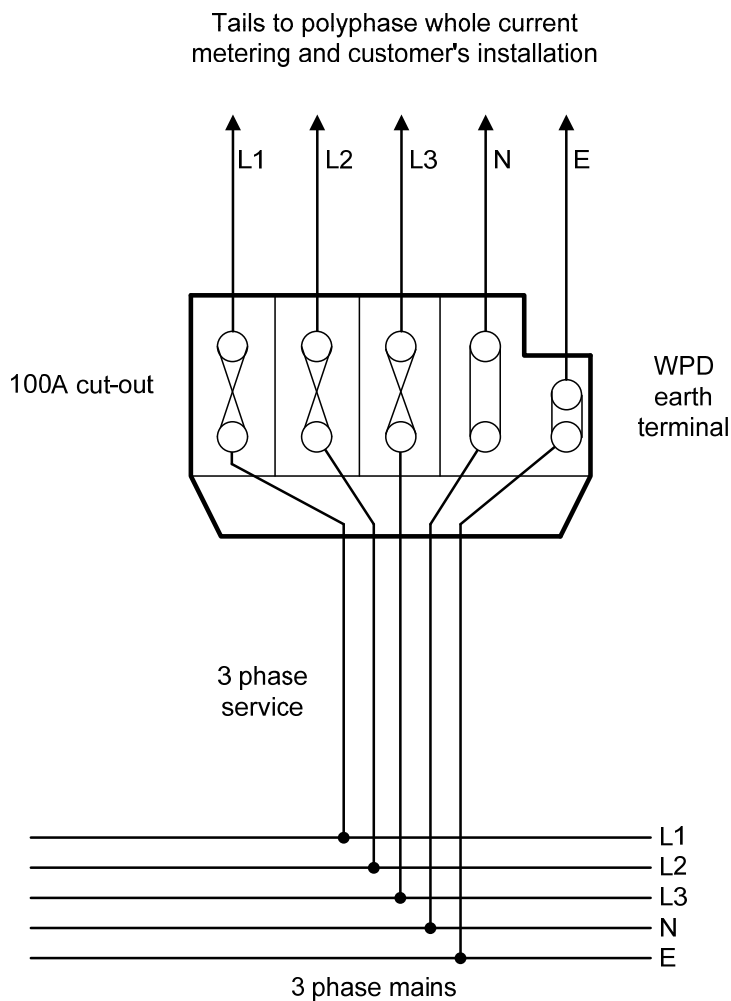

**Notes:**

- 1) Maximum cut-out fuse size is normally 80A;
- 2) Cut-out fuse size and maximum load may be increased to 100A if conditions in 3.3.2 are satisfied;
- 3) Service cable must have a continuous rating above the cut-out fuse rating;
- 4) SNE label shall be placed adjacent to cut-out.

**FIGURE 5C**

**Three-phase Directly Earthed Connection Arrangement; maximum load is normally limited to 80A per phase**

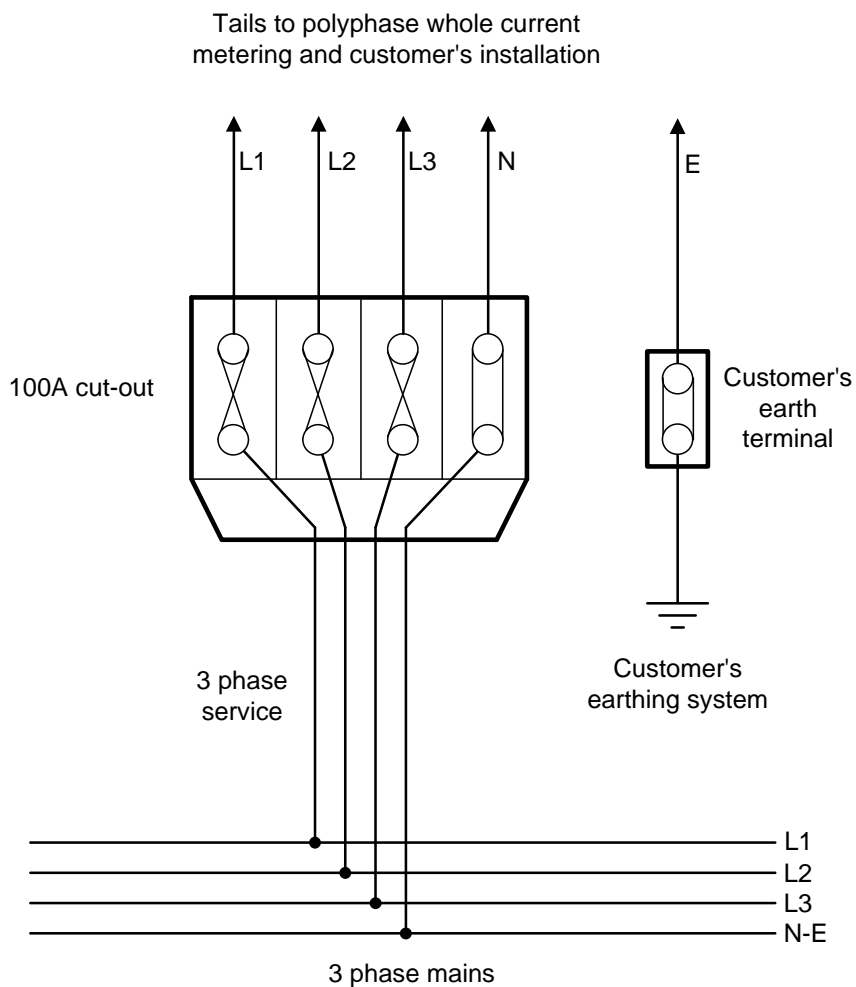

**Notes:**

- 1) Maximum cut-out fuse size is normally 80A;
- 2) Cut-out fuse size and maximum load may be increased to 100A if conditions in 3.3.2 are satisfied;
- 3) Service cable must have a continuous rating above the cut-out fuse rating;
- 4) Customer provides own earthing system and earthing terminal;
- 5) A direct earthing label shall be placed adjacent to cut-out.

**FIGURE 5D**

**Typical Metering / Customer Arrangement; three-phase connection with poly-phase metering and with a maximum load normally limited to 80A per phase**

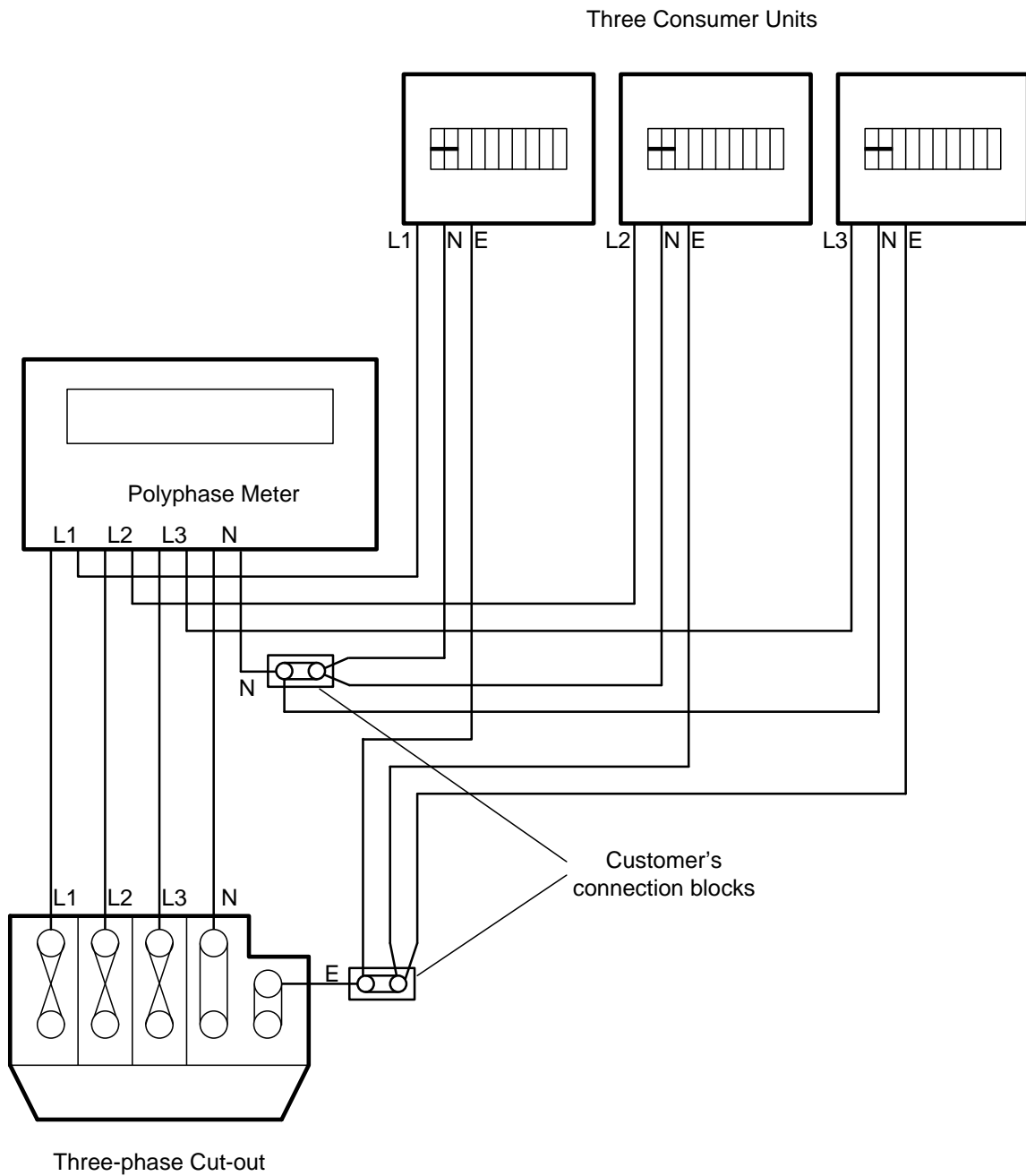

**Notes:**

- 1) The above arrangement utilising three consumer units is only suitable if all the load is single-phase. If a multiphase load is installed (e.g. three-phase motor) the tails must be terminated in a three-phase main switch so that all phases are switched together.

**FIGURE 6A**

**Three-phase PME Connection Arrangement; loads above 80A per phase**

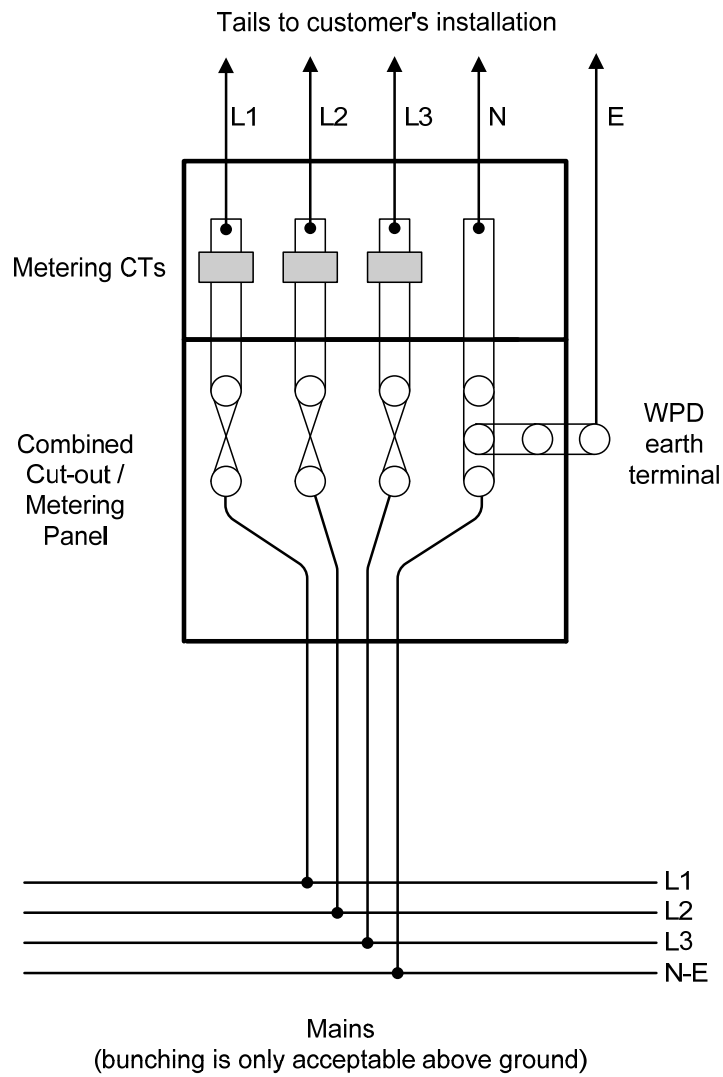

**Notes:**

- 1) Drawing is based on a combined cut-out / CT metering panel;
- 2) Polyphase whole current metering may be used for loads up to 100A per phase. CT metering (as shown above) is required for loads over 100A per phase;
- 3) Incoming cable and meter tails must have a continuous rating above the cut-out fuse rating;
- 4) PME label shall be placed adjacent to cut-out.



**FIGURE 6B**      **Three-phase SNE Connection Arrangement; loads above 80A per phase**

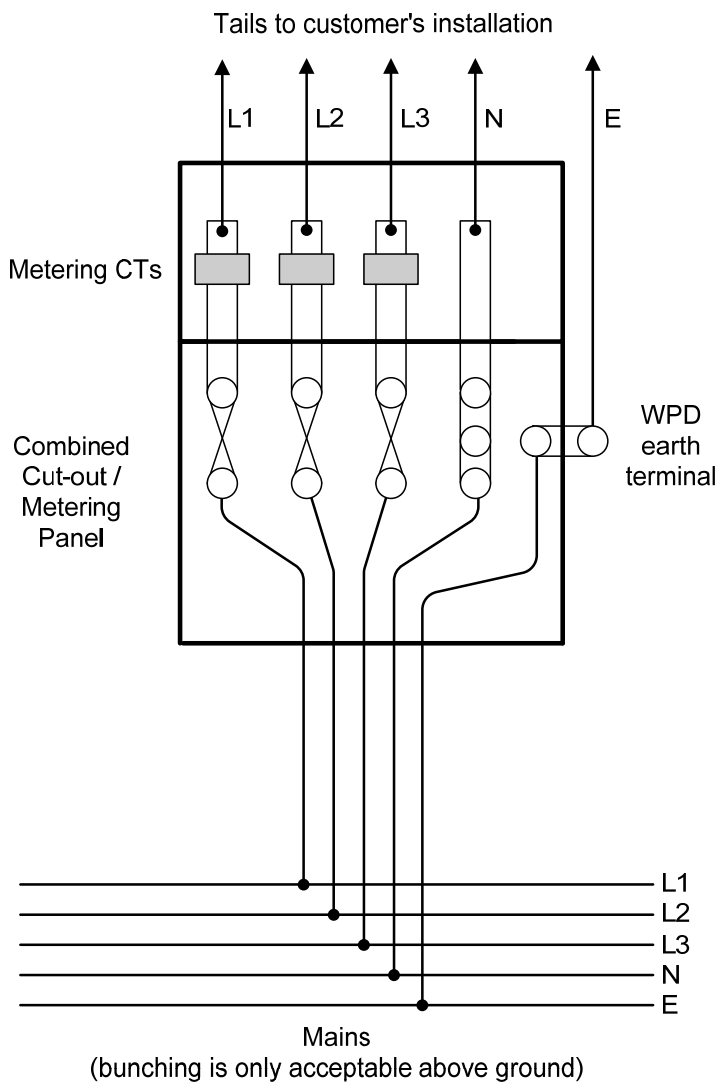

**Notes:**

- 1) Drawing is based on a combined cut-out / CT metering panel;
- 2) Polyphase whole current metering may be used for loads up to 100A per phase. CT metering (as shown above) is required for loads over 100A per phase;
- 3) Incoming cable and meter tails must have a continuous rating above the cut-out fuse rating;
- 4) SNE label shall be placed adjacent to cut-out.

**FIGURE 6C**

**Three-phase Directly Earthed Connection Arrangement; loads above 80A per phase**

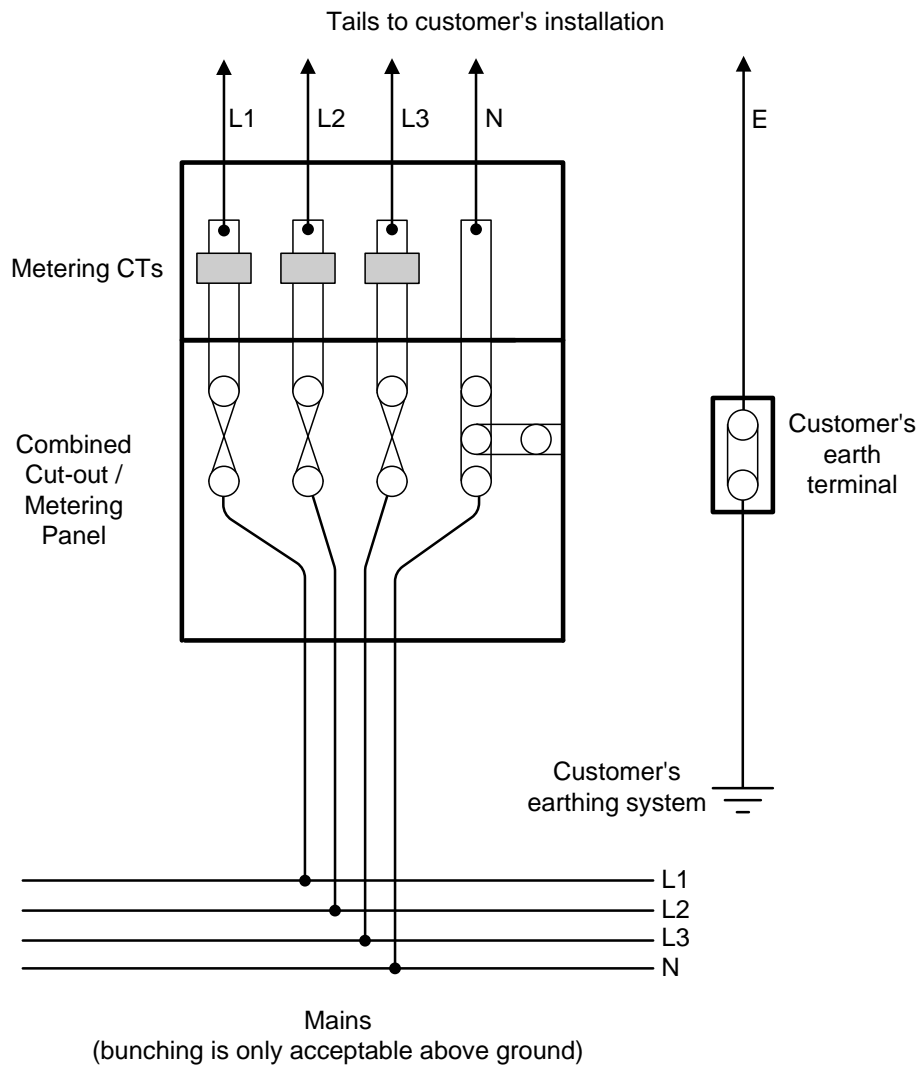

**Notes:**

- 1) Drawing is based on a combined cut-out / CT metering panel;
- 2) Polyphase whole current metering may be used for loads up to 100A per phase. CT metering (as shown above) is required for loads over 100A per phase;
- 3) Incoming cable and meter tails must have a continuous rating above the cut-out fuse rating;
- 4) Customer provides own earthing system and earthing terminal;
- 5) A direct earthing label shall be placed adjacent to cut-out.

**FIGURE 7 Isolation Switches**



**FIGURE 8**

**Typical Isolation Switch Application**

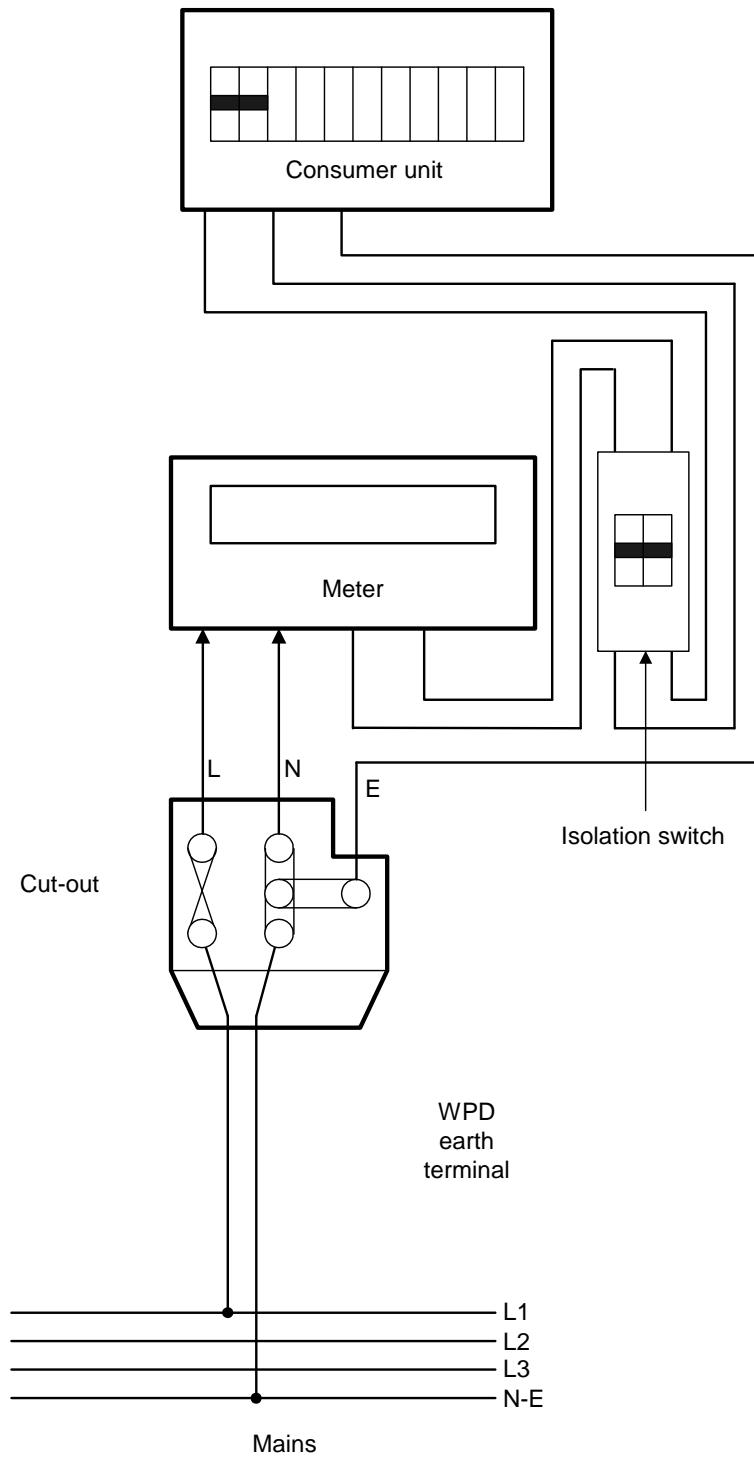

**FIGURE 9 CABLE ENTRY REQUIREMENTS FOR WAVECON CABLE DRAW PIT OPTION**

**This option is suitable for 95, 185 and 300 Wavecon cable**

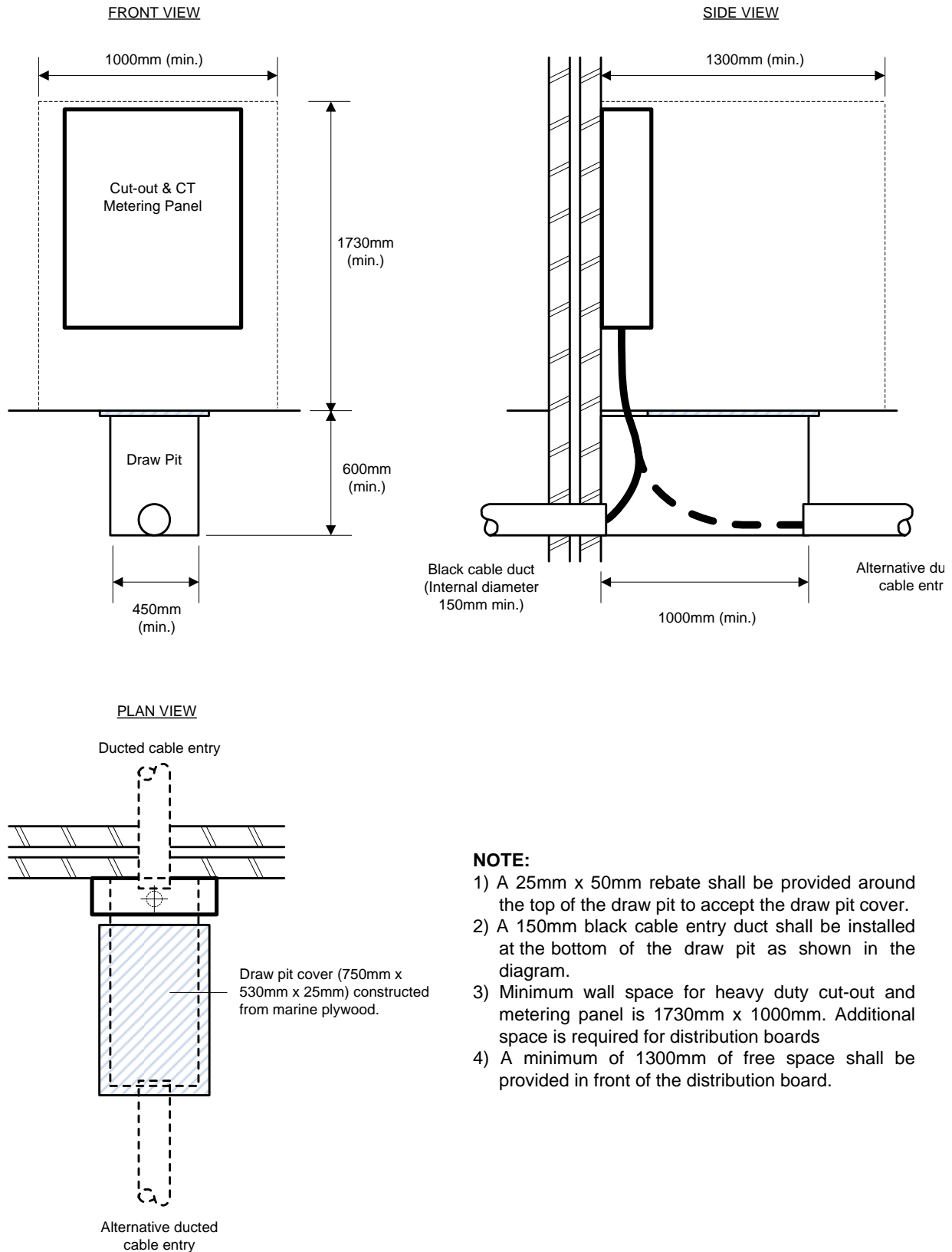

**NOTE:**

- 1) A 25mm x 50mm rebate shall be provided around the top of the draw pit to accept the draw pit cover.
- 2) A 150mm black cable entry duct shall be installed at the bottom of the draw pit as shown in the diagram.
- 3) Minimum wall space for heavy duty cut-out and metering panel is 1730mm x 1000mm. Additional space is required for distribution boards
- 4) A minimum of 1300mm of free space shall be provided in front of the distribution board.

**FIGURE 10 CABLE ENTRY REQUIREMENTS FOR 95 WAVECON CABLE– SLOW BEND DUCT OPTION**

**This Option is only suitable for 95 Wavecon cable**

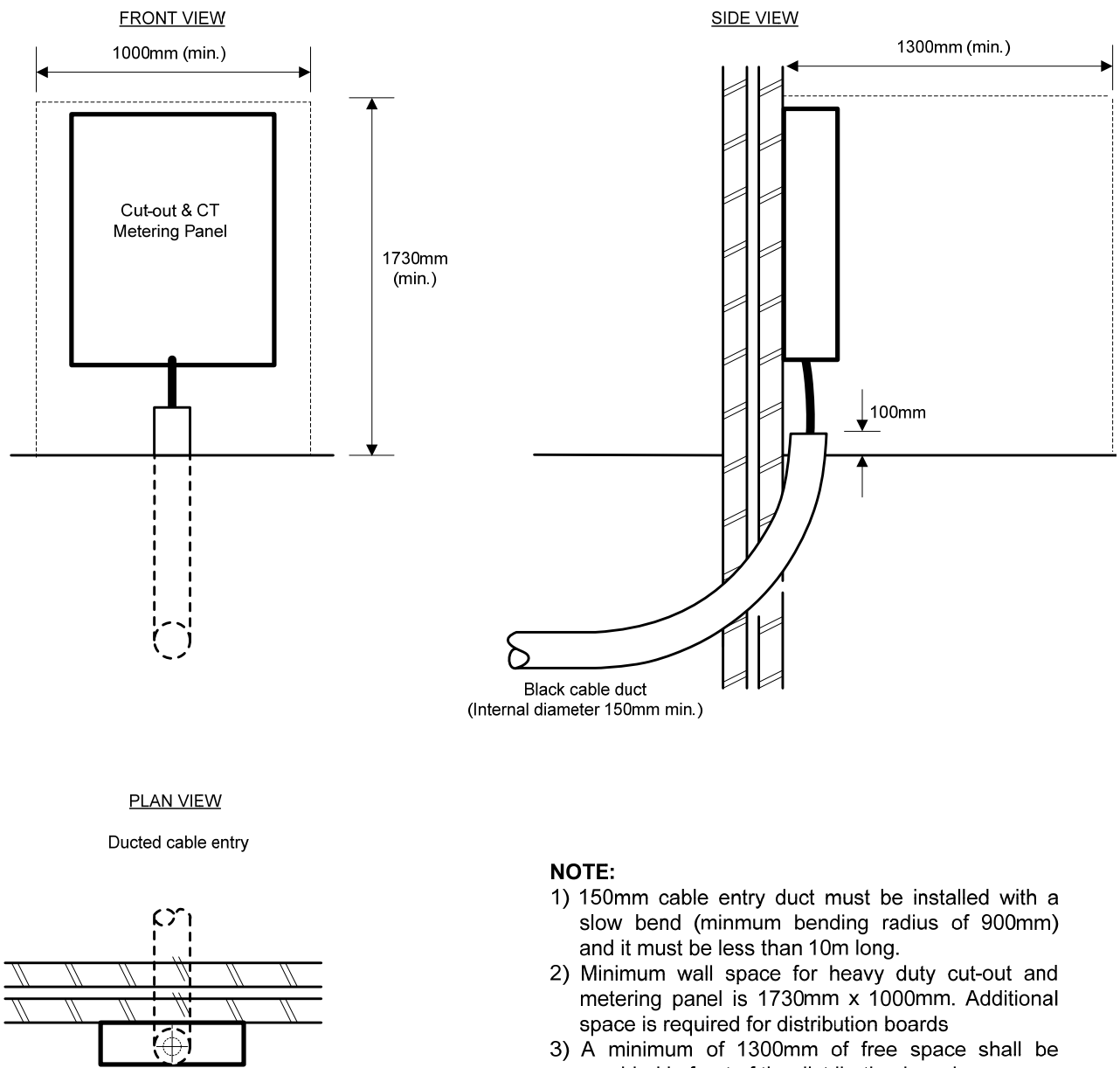

## **APPENDIX A**

### **SUPERSEDED DOCUMENTATION**

This document supersedes ST:SD5D/1 dated May 2009 which should now be withdrawn.

## **APPENDIX B**

### **ASSOCIATED DOCUMENTATION**

ST:SD5A      Design of low voltage domestic connections  
ST:SD5C      Connection arrangements for flats, maisonettes and bedsits  
ST:SD6B      Connection design for low voltage loads between 69kVA and 1000kVA

## **APPENDIX C**

### **IMPLEMENTATION OF POLICY**

For WPD staff this Standard Technique is to be implemented with immediate effect for new and substantially modified connections. Managers shall ensure that all staff involved in the design, installation, maintenance and operation of the LV system are familiar with, and follow, the requirements of this document.

Independent Connection Providers (ICPs) may follow the requirements of ST:SD5D/1 or of this document (ST:SD5D/2) for a period of up to 3 months from the issue of this document. After this date, all new and substantially modified connections shall comply with ST:SD5D/2.

Where any difficulty is encountered in the application of this Standard Technique the author shall be notified who will determine whether a variation is appropriate.

## **APPENDIX D**

### **IMPACT ON COMPANY POLICY**

The requirements for multi-service distribution boards and multi-occupancy buildings have been removed from this document. These aspects are now included in ST:SD5C, as amended.

The arrangements described in section 3.1.3 and in figures 2A, 2B, 2C and 2D are only applicable where the mains cable or overhead line is single phase.

## **APPENDIX E**

### **KEY WORDS**

Cut-out, multi-service distribution board, isolation switch, PME, SNE, Direct Earthing.